



# SIGHT LEVEL GAUGES

## ALG Series



Part Numbers				Dimensions		
Back Mount Gauges Sight Only	Back Mount Gauges with Thermometer	Front Mount Gauges Sight Only	Front Mount Gauges with Thermometer	A Mounting Centers	B Sight Glass	C Overall Length
ALG-3	ALG-3T	N/A	N/A	3"	1 1/2"	4 5/8"
ALG-5	ALG-5T	FMALG-5	FMALG-5T	5"	3 1/2"	6 5/8"
ALG-10	ALG-10T	FMALG-10	FMALG-10T	10"	8 1/2"	11 5/8"

• For Viton seals add suffix -V (i.e. ALG5T-V)

• For EPDM seals add suffix -EP (i.e. ALG5T-EP)

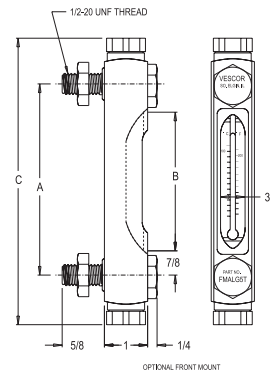
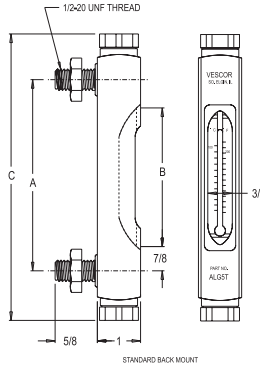

VESCOR Standard Fluid Sight Level Gauges are available in three sizes 3", 5" and 10". Gauges are available with or without thermometer in standard back mount design or optional front mount design.

### Benefits and Features:

- Provides positive check of fluid level and temperature
- Rugged aluminum construction
- Durable pyrex glass tube
- 70 PSI max. pressure
- Thermometer with readings in centigrade and fahrenheit
- Buna-N O'-ring seals
- 250° F maximum temperature
- Minimum protrusion from reservoir

### Mounting Information

- Standard back mount gauges require access to reservoir. (2) 17/32 diameter holes to match mounting centers are required.
- Standard front mount gauges do not require access to reservoir. Gauge can be installed from the outside on (2) 1/2-20 tapped holes (when wall thickness permits) or (2) 1/2-20 hex nuts welded inside reservoir to match mounting centers.

### Ordering Information

- Order sight level gauge by VESCOR part numbers

## SGC Series

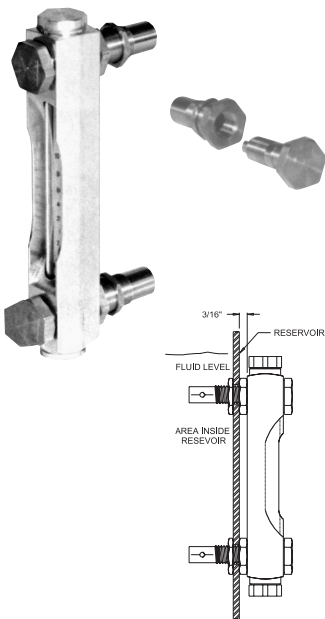

### VESCOR QUICK CHANGE SIGHT GAUGE CHECK®

Check valve provides the necessary means to replace the sight gauge quickly and easily.

### Benefits and Features:

- Ideal for new reservoir applications
- May be field installed with slight modification to existing reservoir
- Compatible with most types of hydraulic oil
- Provides positive shut-off of fluid to sight gauge
- Readily available from stock
- Sight gauge can be removed and replaced without draining reservoir
- Minimal spillage of fluid
- Low cost

### Mounting Information:

- **Existing reservoir applications:** Access to reservoir is required. (2) 21/32 diameter holes to match mounting centers are required. From inside reservoir install check portion of sight gauge check. From outside reservoir install sight gauge. Sight Gauge may now be removed and/or changed at any time without draining reservoir. (Note-reservoir may have to be drained to a level below lowest mounting hole for initial installation.)
- **New reservoir applications:** Before filling reservoir drill (2) 21/32 diameter holes to match mounting centers. From inside install check portion of Sight Gauge Check. From outside reservoir install sight gauge. Fill reservoir. Sight Gauge may now be removed and/or changed at any time without draining reservoir.

Vescor Part Number	Description
SGC5	5" Front Mount Sight Gauge with Quick Change Sight Gauge Check
SGC10	10" Front Mount Sight Gauge with Quick Change Sight Gauge Check

### Ordering Information:

- Order Quick Change Sight Gauge Check by VESCOR Part Number