



GAS ENGINE ADAPTERS

Mounting Flange Information

Easy Assembly Pump to Gas Engine

1. Place coupling half for engine on engine shaft and lightly tighten set screw.
2. Mount pump to pump end of gas engine adapter.
3. Place coupling half for pump on pump shaft and lightly tighten set screw.
4. Position coupling insert. Bolt gas engine adapter with pump installed to the face of the gas engine.
5. Adjust coupling thru access opening. Thoroughly tighten set screws and mounting bolts.

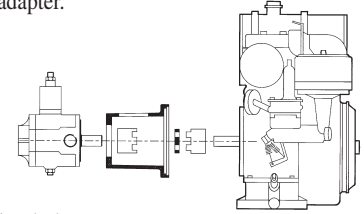

Vescor® GAS ENGINE ADAPTERS

- Increases Assembly Time – Bolt Mount to Side of Gas Engine
- Are Made of Lightweight but Strong Cast Aluminum
- Proper Shaft Alignment Assured
- Reduced Cost – No Need for Foot Brackets, Shims, or Risers
- Provides a Clean, Neat Appearance for Your Finished Product

Note: Not all mounting flanges are available -consult factory

PEM-F-Flange

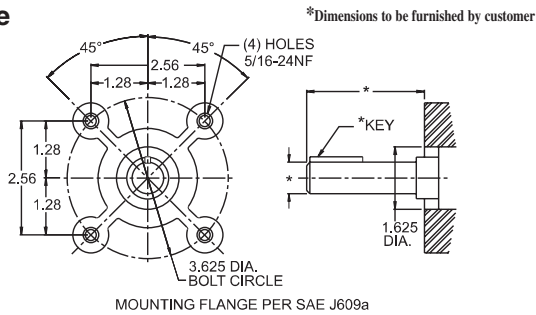

LB152-Flange

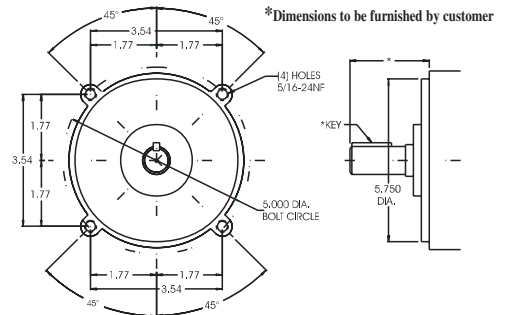

LB170-Flange

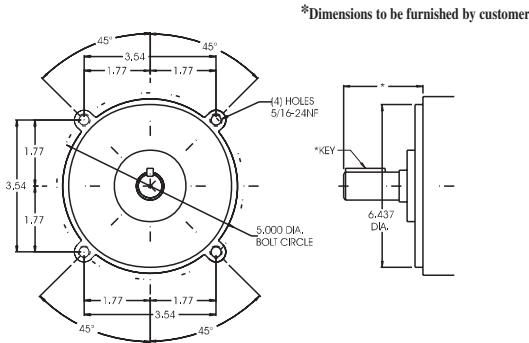

PEM-G-Flange

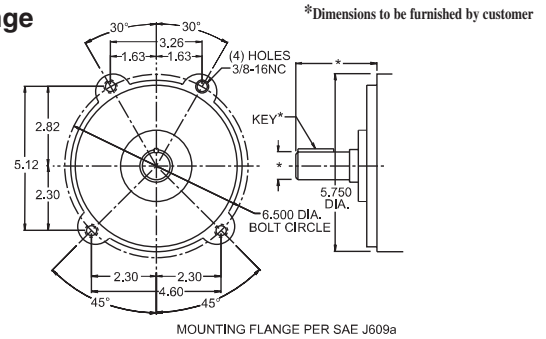

PEM-H-Flange

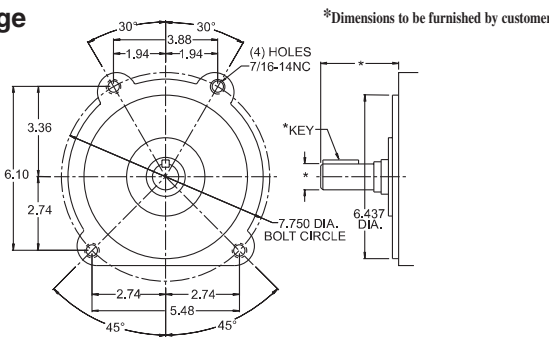

PEM-HH-Flange

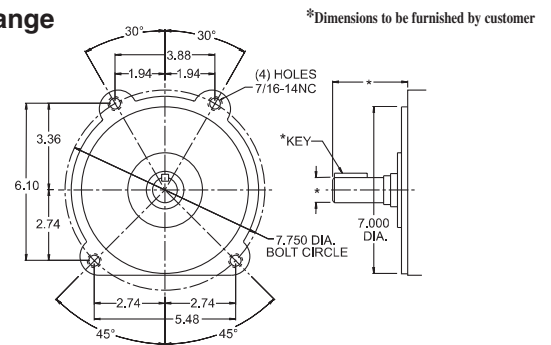

PEM-K-Flange

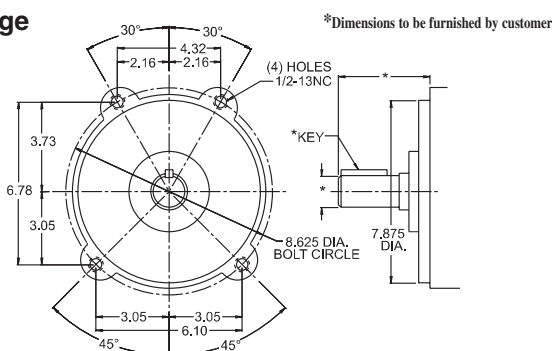

PEM-J-Flange

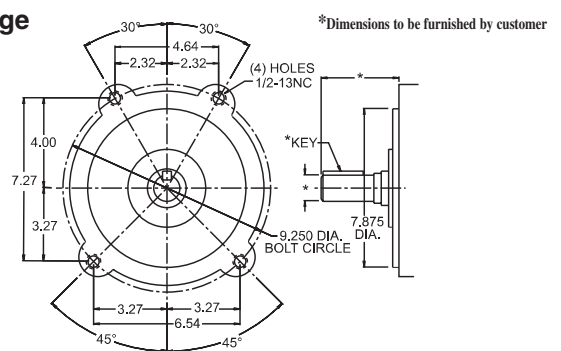



GAS ENGINE ADAPTERS

PEM-F Flange

SAE J609a

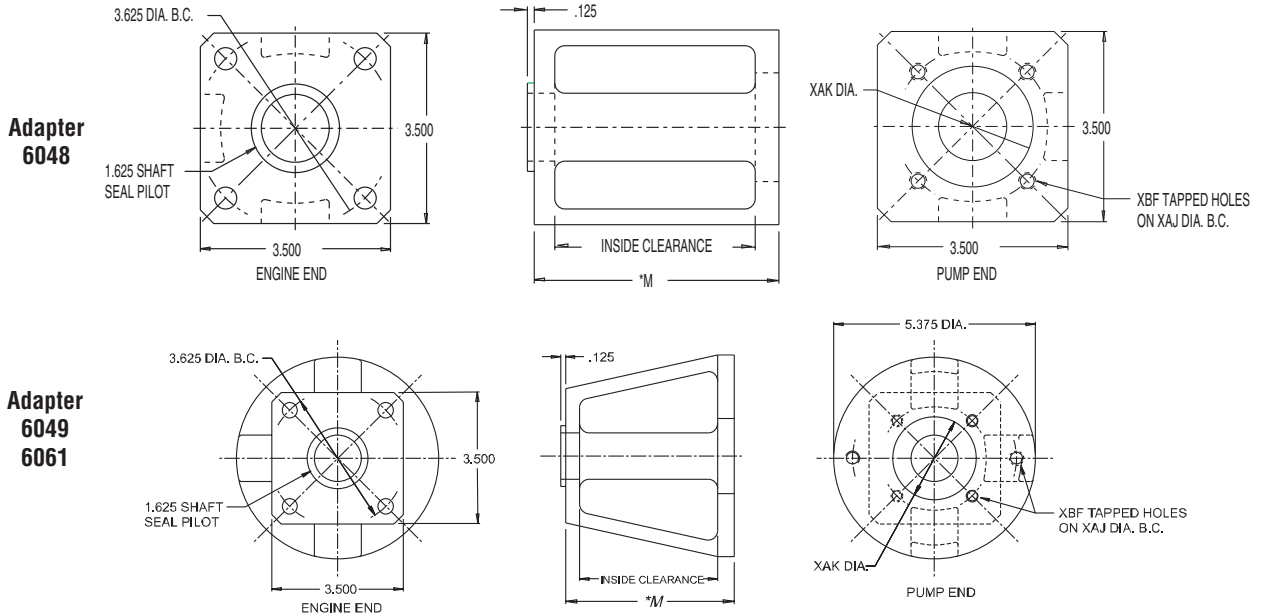

ADAPTS TO:

- Engines** • Briggs & Straton 3-5 H.P. • Wisconsin EY18-3W • Other engines with 1.625 dia. shaft seal pilot
Pumps • 4F17 4 bolt with 1.781" dia. pilot (6048) • SAE "AA" 2 bolt with 2" dia. pilot (6049) • SAE "A" 2 bolt with 3/4" dia. pilot (6061)
Standard Metric Series Pump Flanges also available (Consult factory)

Vescor Part Number	Pump Type	Pump Mounting Flange	MAX Cplg. Dia.	XAJ Bolt Circle	XAK Pump Pilot	XBF Mounting Holes	M Face to Face	Inside Clearance
6048	USA 4F17	4 Bolt	2.75	2.840	1.781	5/16-18NC	4.500	3.63
6049	SAE AA	2 Bolt	2.75	3.250	2.001	3/8-16NC	4.500	3.63
6061	SAE A	2 Bolt	2.75	4.187	3.251	3/8-16NC	4.687	3.63

LB152 Flange

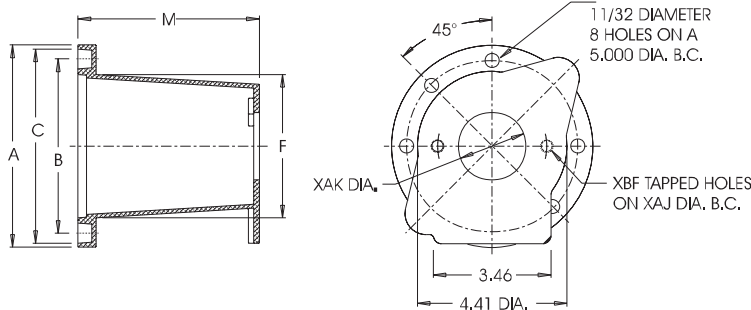

ADAPTS TO:

- Briggs & Straton Engines**
- Vanguard 7.5-23 H.P.
 - I/C 7-18 H.P.
 - Industrial Plus 8-11 H.P.
 - Standard Engine 8-11 H.P.

Other Gas Engines with 5.750" pilot and 5.000" diameter bolt circle

Vescor Part Number	Pump Type	Pump Mounting Flange	XAJ Bolt Circle	XAK Pump Pilot	XBF Mounting Holes	Dimensions				M Face to Face
						A	B	C	F	
LB152825A	SAE A	2 Bolt	4.187	3.251	3/8-16NC	5.98	5.00	5.75	4.33	5.59
LB152101A	SAE B	2 Bolt	5.750	4.001	1/2-13NC	5.98	5.00	5.75	4.33	5.59

NOTE: WITH VESCORS' POLICY OF CONSTANTLY IMPROVING ITS PRODUCTS, SPECIFICATIONS ARE SUBJECT TO CHANGE WITHOUT NOTICE.



GAS ENGINE ADAPTERS

PEM-G Flange

SAE J609a

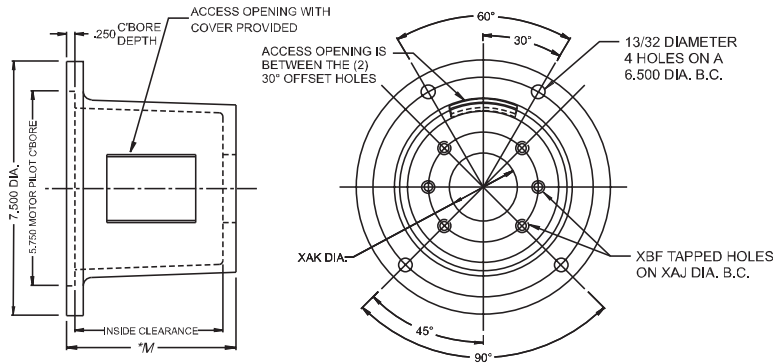

ADAPTS TO:

Engines

- Briggs & Straton 10-18 H.P. Aluminum Engines
- Kohler 6-8 H.P.
- Wisconsin S-8d & TRA-12D
- Other engines with similar mounting

Pumps

- 4F17 4 bolt with 1.781" dia. pilot (6025/6021)
- SAE "AA" 2 bolt with 2" dia. pilot (6023/6020)
- SAE "A" 2 bolt with 3 1/4" dia. pilot (6024/6019)

Standard Metric Series Pump Flanges also available - Consult factory

Vescor Part Number	Pump Type	Pump Mounting Flange	Max Cplg. Dia.	XAJ Bolt Circle	XAK Pump Pilot	XBF Mounting Holes	M Face to Face	Inside Clearance
6025 6021	USA 4F17	4 Bolt	4.00	2.840	1.781	5/16-18NC	5.000 5.625	4.00 4.50
6023 6020	SAE AA	2 Bolt	4.00	3.250	2.001	3/8-16NC	5.000 5.625	4.00 4.50
6024 6019	SAE A	2 Bolt	4.00	4.187	3.251	3/8-16NC	5.000 5.625	4.00 4.50

PEM-G Flange

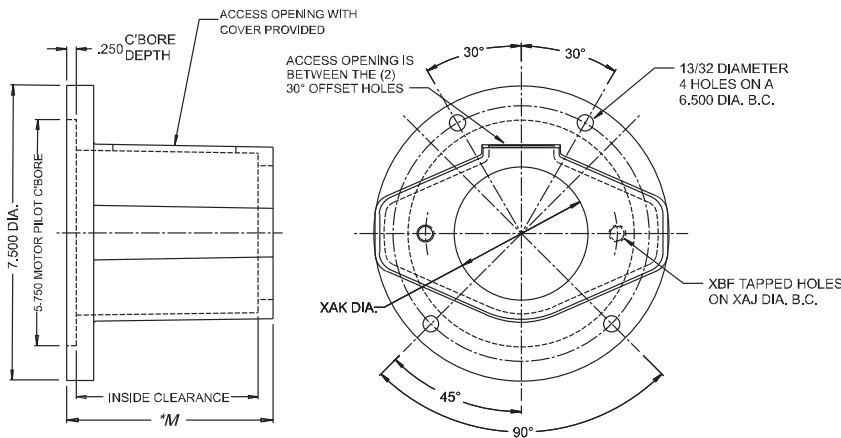

ADAPTS TO:

Engines

- Briggs & Straton 10-18 H.P. Aluminum and Cast Iron
- Kohler 6-8 H.P.
- Wisconsin S-8D & TRA-12D
- Other engines with similar mounting

Pumps

- SAE "B" 2 bolt with 4" dia. pilot (196899)

Standard Metric Series Pump Flanges also available - Consult factory

Vescor Part Number	Pump Type	Pump Mounting Flange	Max Cplg. Dia.	XAJ Bolt Circle	XAK Pump Pilot	XBF Mounting Holes	M Face to Face	Inside Clearance
196899	SAE B	2 Bolt	3.50	5.750	4.001	1/2-13NC	5.250	4.62



GAS ENGINE ADAPTERS

LB170 Flange

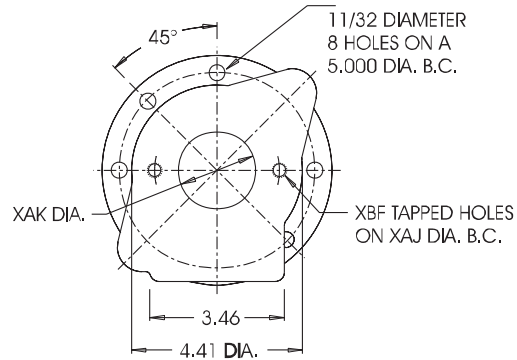
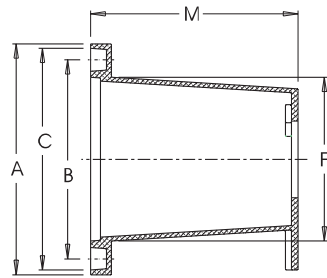

ADAPTS TO:

Briggs & Stratton Engines

- 1/C 9, 10, 15, 18 H.P.

Other Gas Engines with 6.437" pilot and 5.000" diameter bolt circle

Vescor Part Number	Pump Type	Pump Mounting Flange	XAJ Bolt Circle	XAK Pump Pilot	XBF Mounting Holes	A	B	C	F	M Face to Face
LB170825A	SAE A	2 Bolt	4.187	3.251	3/8-16NC	6.69	5.00	6.44	4.33	5.59
LB170101A	SAE B	2 Bolt	5.750	4.001	1/2-13NC	6.59	5.00	6.44	4.33	5.59

PEM-H Flange

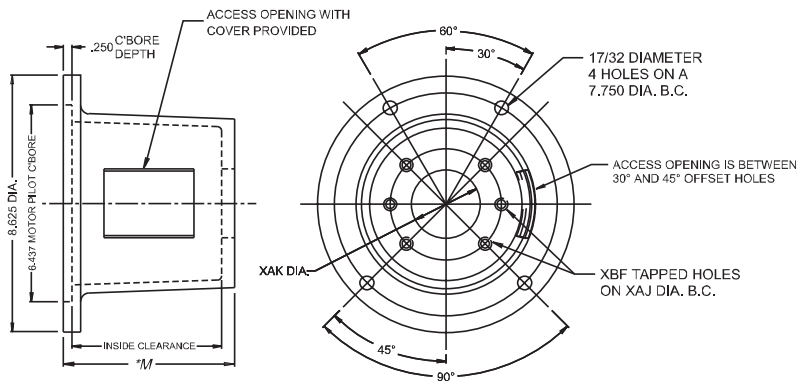

ADAPTS TO:

Engines

- Briggs & Stratton 6-18 H.P. Aluminum and Cast Iron
- Kohler 6-23 H.P.
- Wisconsin 6-23.8 H.P.
- Other engines with similar mounting

Pumps

- 4F17 4 bolt with 1.781" dia. pilot (6063)
- SAE "AA" 2 bolt with 2" dia. pilot (6064)
- SAE "A" 2 bolt with 3 1/4" dia. pilot (6067)

Standard Metric Series Pump Flanges also available - Consult factory

Vescor Part Number	Pump Type	Pump Mounting Flange	MAX Cplg. Dia.	XAJ Bolt Circle	XAK Pump Pilot	XBF Mounting Holes	M Face to Face	Inside Clearance
6063	USA 4F17	4 Bolt	4.00	2.840	1.781	5/16-18NC	5.625	4.50
6064	SAE AA	2 Bolt	4.00	3.250	2.001	3/8-16NC	5.625	4.50
6067	SAE A	2 Bolt	4.00	4.187	3.251	3/8-16NC	5.625	5.50



GAS ENGINE ADAPTERS

PEM-HH Flange

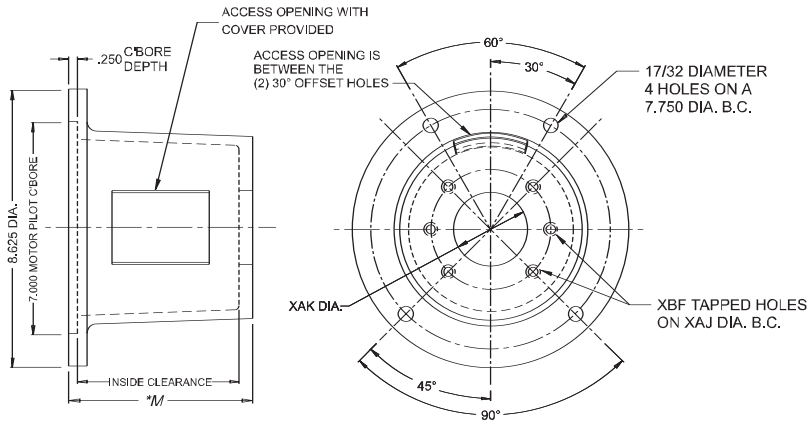

ADAPTS TO:

Engines

- Briggs & Stratton 6-18 H.P. Aluminum and Cast Iron
- Kohler 6-23 H.P.
- Wisconsin 6-23.8 H.P.
- Other engines with similar mounting

Pumps

- 4F17 4 bolt with 1.781" dia. pilot (6022)
- SAE "AA" 2 bolt with 2" dia. pilot (6018)
- SAE "A" 2 bolt with 3 1/4" dia. pilot (6017)

Standard Metric Series Pump Flanges also available - Consult factory

Vescor Part Number	Pump Type	Pump Mounting Flange	MAX Cplg. Dia.	XAJ Bolt Circle	XAK Pump Pilot	XBF Mounting Holes	M Face to Face	Inside Clearance
6022	USA 4F17	4 Bolt	4.00	2.840	1.781	5/16-18NC	5.625	4.50
6018	SAE AA	2 Bolt	4.00	3.250	2.001	3/8-16NC	5.625	4.50
6017	SAE A	2 Bolt	4.00	4.187	3.251	3/8-16NC	5.625	4.50

PEM-HH Flange

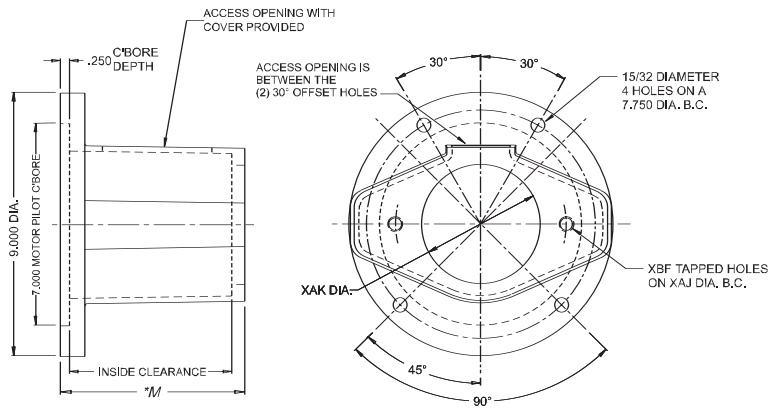

ADAPTS TO:

Engines

- Briggs & Stratton 10-16 H.P. Cast Iron
- Kohler 10-23 H.P.
- Wisconsin TJD and AGND
- Other engines with similar mounting

Pumps

- SAE "A" 2 bolt with 3 1/4" dia. pilot (196199)
- SAE "B" 2/4 bolt with 4" dia. pilot (196399)
- SAE "C" 2 bolt with 5" dia. pilot (196599)

Standard Metric Series Pump Flanges also available - Consult factory

Vescor Part Number	Pump Type	Pump Mounting Flange	MAX Cplg. Dia.	XAJ Bolt Circle	XAK Pump Pilot	XBF Mounting Holes	M Face to Face	Inside Clearance
196199	SAE A	2 Bolt	3.50	4.187	3.251	3/8-16NC	7.00	5.125
196399	SAE B	2 Bolt 4 Bolt	3.50	5.750 5.000	4.001	1/2-13NC	7.00	5.125
196599	SAE C	2 Bolt	3.50	7.125	5.001	5/8-11NC	7.00	5.125



GAS ENGINE ADAPTERS

PEM-J Flange

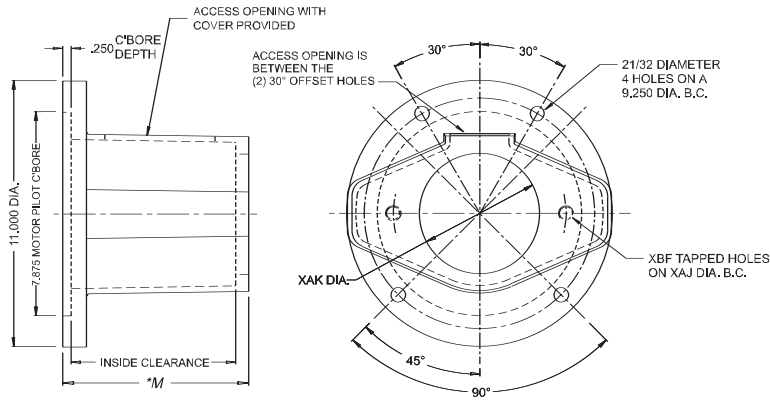

ADAPTS TO:

Engines

- Wisconsin W4(1770) (2460), AGND, UHLD
- Other engines with similar mounting

Pumps

- SAE "B" 2 bolt with 4" dia. pilot (196299)
- SAE "C" 2 bolt with 5" dia. pilot (196499)

Standard Metric Series Pump Flanges also available - Consult factory

Vescor Part Number	Pump Type	Pump Mounting Flange	MAX Cplg. Dia.	XAJ Bolt Circle	XAK Pump Pilot	XBF Mounting Holes	M Face to Face	Inside Clearance
196299	SAE B	2 Bolt	5.50	5.750	4.001	1/2-13NC	9.75	8.187
196499	SAE C	2 Bolt	5.50	7.125	5.001	5/8-11NC	9.75	8.187

Custom Adapters

Vescor will manufacture Pump Motor / Engine Adapters for Custom Applications

- Steel Adapters
- Special Pump Mounts other than SAE
- Diesel or Gasoline Adapters
- Steel Foot Mounts
- Custom "Face to Face" dimensions

Please consult Vescor for all your Pump Adapter requirements