

# IMMERSION HEATERS

## IN-TANK OIL COOLERS

## AIR OIL COOLERS

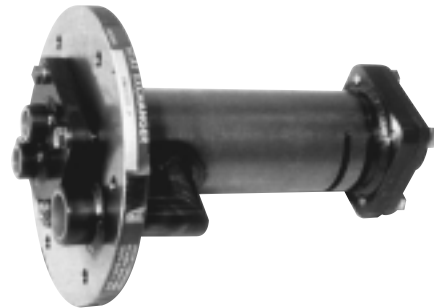
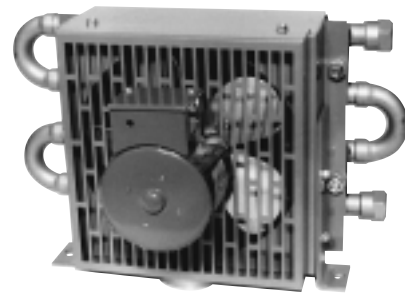

**VESCOR<sup>®</sup>**

*Specialists in  
Hydraulic Reservoirs  
and Accessories*





### Features

- Keeps oil at 60° to 70° F.
- Automatic built-in fixed setting thermostat.
- Will not burn oil
- UL recognized and CSA certified
- Weatherproof wiring enclosure (NEMA 4)

### Notes

1. Heaters must be mounted horizontally and immersed at all times.
2. Heaters over 10 amps, 480 volt, or three phase, must be used with a contactor. See instruction sheet.
3. Three phase available on ET 8 models.  
Add -3 to the model number. Example: ET 8-2502-3.
4. For tanks larger then 500 gallon use multiple heaters or consult factory for information on higher wattage heaters.
5. Amps = Watts ÷ Volts for single phase.
6. Amps = Watts ÷ (Volts x 1.73) for three phase.

next print move over brass type

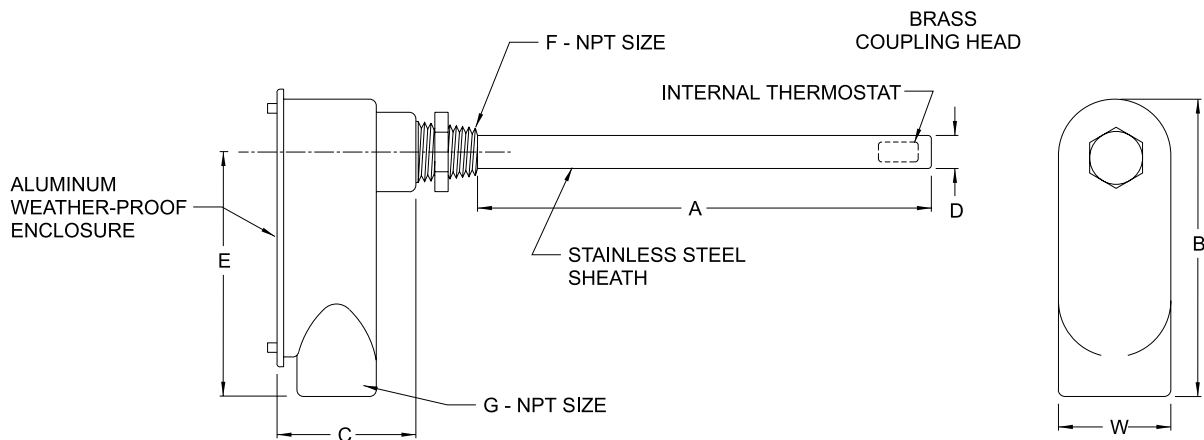

VESCOR PART NUMBER	RESERVOIR SIZE - GALS	WATTAGE	VOLTS	NPT SIZE		DIMENSIONS					
				F	G	A	B	C	D	E	W
ET 2-121	up to 10	125	120	1/2"	1/2"	7"	4.5"	2.2"	.62"	3.6"	1.3"
ET 2-251	up to 25	250	120	1/2"	1/2"	8"	4.5"	2.2"	.62"	3.6"	1.3"
ET 2-252	up to 25	250	240	1/2"	1/2"	8"	4.5"	2.2"	.62"	3.6"	1.3"
ET 3-501	25-50	500	120	3/4"	3/4"	12.6"	5.1"	2.5"	.75"	4.1"	1.5"
ET 3-502	25-50	500	240	3/4"	3/4"	12.6"	5.1"	2.5"	.75"	4.1"	1.5"
ET 3-504	25-50	500	480	3/4"	3/4"	12.6"	5.1"	2.5"	.75"	4.1"	1.5"
ET 3-1001	50-100	1000	120	3/4"	3/4"	22.6"	5.1"	2.5"	.75"	4.1"	1.5"
ET 3-1002	50-100	1000	240	3/4"	3/4"	22.6"	5.1"	2.5"	.75"	4.1"	1.5"
ET 3-1004	50-100	1000	480	3/4"	3/4"	22.6"	5.1"	2.5"	.75"	4.1"	1.5"
ET 8-2502	100-250	2500	240	2"	1-1/4"	23"	8.2"	3.7"	1.9"	6.7"	2.8"
ET 8-2504	100-250	2500	480	2"	1-1/4"	23"	8.2"	3.7"	1.9"	6.7"	2.8"
ET 8-5002	250-500	5000	240	2"	1-1/4"	44"	8.2"	3.7"	1.9"	6.7"	2.8"
ET 8-5004	250-500	5000	480	2"	1-1/4"	44"	8.2"	3.7"	1.9"	6.7"	2.8"

NOTE: WITH VESCORS' POLICY OF CONSTANTLY IMPROVING ITS PRODUCTS, SPECIFICATIONS ARE SUBJECT TO CHANGE WITHOUT NOTICE.

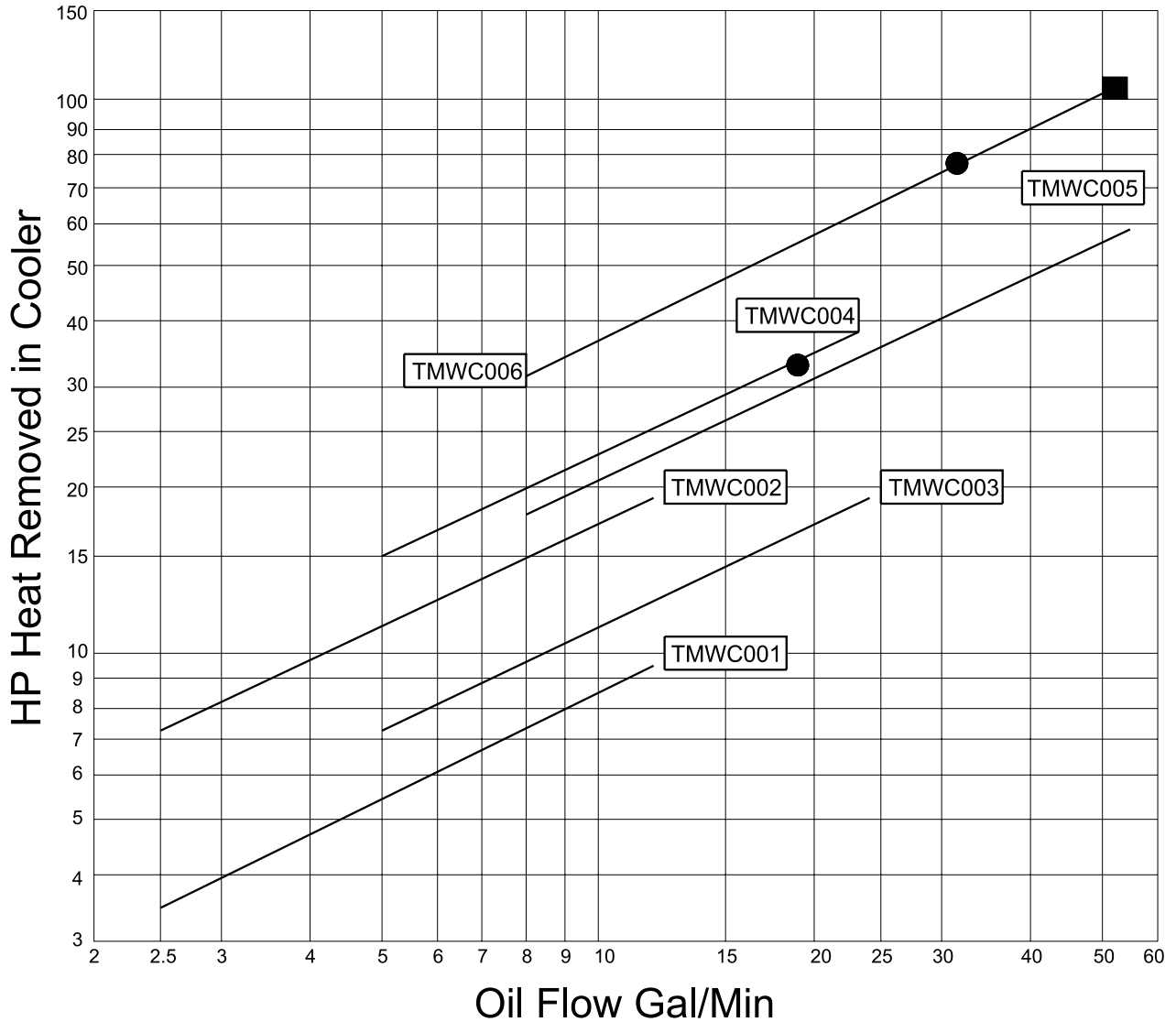

## Cooler Selection Procedure

- Curves are based on a 40°F approach temperature, a 2:1 oil to water ratio and an average oil viscosity of 100 SSU. Example: oil leaving cooler at 125°F with 85°F cooling water (125°F - 85°F = 40°F). The 2:1 oil to water ratio means that for every GPM of oil circulated, a minimum of 1/2 GPM of water must be circulated to obtain the curve results.
- Oil pressure drop coding: ● = 5 PSI, ■ = 10 PSI. Curves having no pressure drop symbol indicate that the oil pressure drop is less than 5 PSI to the highest oil flow rate for that curve. Multiply curve oil pressure drop by Correction B.
- Corrections for approach temperature and oil viscosity:

### VISCOSITY CORRECTIONS

Avg. Oil SSU	A	B
50	0.84	0.6
100	1.00	1.0
200	1.14	2.0
300	1.24	3.1
400	1.31	4.1
500	1.37	5.1

$$\text{HP Heat Removed in Cooler} = \text{HP actual} \times \left\{ \frac{40^\circ\text{F}}{\text{Approach Temp}} \right\} \times \text{Correction A}$$

## IN-TANK OIL COOLERS (Water Cooled)

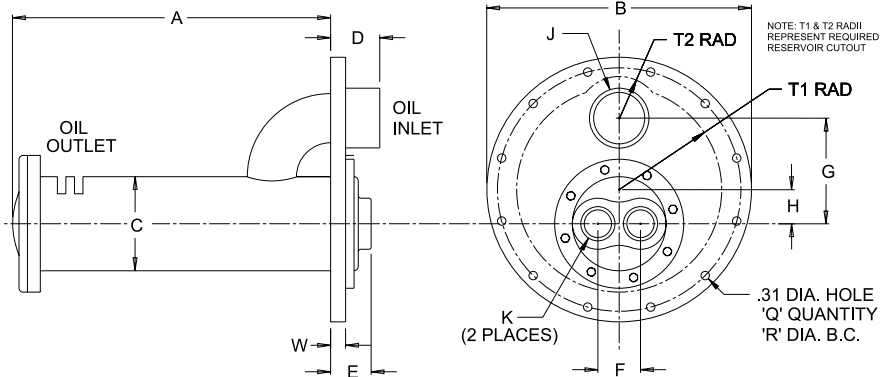
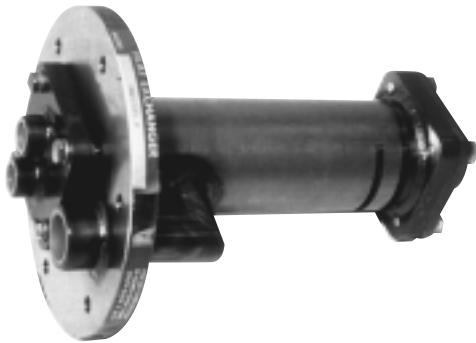

- In-tank design minimizes space requirements and reduces plumbing
  - Internal aluminum fins dramatically increase performance
  - Removable end bonnets allow water passage servicing
  - Steel shell for high strength
- Options
  - SAE or BSPF connections available
  - Internal oil flow bypass-relief (Surge-Cushion®)

MODEL	A	B	C	D NPT or SAE	D BSPF	E	F	G	H	J NPT or BSPF	J SAE	K NPT or BSPF	Q	R	T1	T2	W
TMWC001	8.58	6.75	2.55	1.28	1.52	1.59	1.12	2.44	.50	3/4"	#12	3/8"	6	5.60	2.25	.79	.53
TMWC002	18.58	6.75	2.55	1.28	1.52	1.59	1.12	2.44	.50	3/4"	#12	3/8"	6	5.60	2.25	.79	.53
TMWC003	8.15	9.75	3.52	1.50	1.93	1.50	1.62	3.94	1.28	1-1/2"	#24	1"	12	8.94	4.00	-	.63
TMWC004	18.15	9.75	3.52	1.50	1.93	1.50	1.62	3.94	1.28	1-1/2"	#24	1"	12	8.94	4.00	-	.63
TMWC005	12.50	10.38	5.05	1.62	2.05	2.16	2.38	4.68	1.19	1-1/2"	#24	1-1/2"	12	9.62	4.38	1.12	.66
TMWC006	24.50	10.38	5.05	1.62	2.05	2.16	2.38	4.68	1.19	1-1/2"	#24	1-1/2"	12	9.62	4.38	1.12	.66

All all dimensions in inches. Tank gasket is included. BSPF Threads are 55° Full Form Whitworth.

**NOTE:** We reserve the right to make reasonable design changes without notice. Certified drawings are available upon request.

### SPECIFICATIONS

#### Materials

Shell - Steel  
 Tubes - Copper  
 Fins - Aluminum  
 Tubesheets - Steel  
 Baffles - Steel  
 End Bonnets - Cast Iron  
 Gaskets - Nitrile Rubber/  
 Cellulose Fiber

#### Ratings

Operating Pressure - PSI  
 Shellside - 75  
 Tubeside - 150  
 Test Pressure - PSI  
 Shellside - 75  
 Tubeside - 150  
 Max. Temperature - 250°F

### How To Order



#### Model Series

TMWC001  
 to  
 TMWC006

#### Connections

P = NPT Conn.  
 S = SAE Oil Conn.  
 M = Metric Conn.

#### Surge-Cushion®

Blank - No Surge-Cushion®  
 "R" - Surge-Cushion®

### Maximum Flow Rates

Model Size	Shell Side (GPM)	Tube Side (GPM)
TMWC001/002	20	6
TMWC003/004	65	12

If maximum allowable flow rates are exceeded, premature failure may result.

### SURGE-CUSHION® (optional)

The Surge-Cushion® is a patented protective device designed to internally bypass a portion of the oil flow during cold start conditions, or when sudden flow surges temporarily exceed the maximum flow allowed for a given cooler. This device may replace an external bypass valve, but it is not intended to bypass the total oil flow.

Surge-Cushion is a registered trademark.

NOTE: WITH VESCORS' POLICY OF CONSTANTLY IMPROVING ITS PRODUCTS, SPECIFICATIONS ARE SUBJECT TO CHANGE WITHOUT NOTICE.

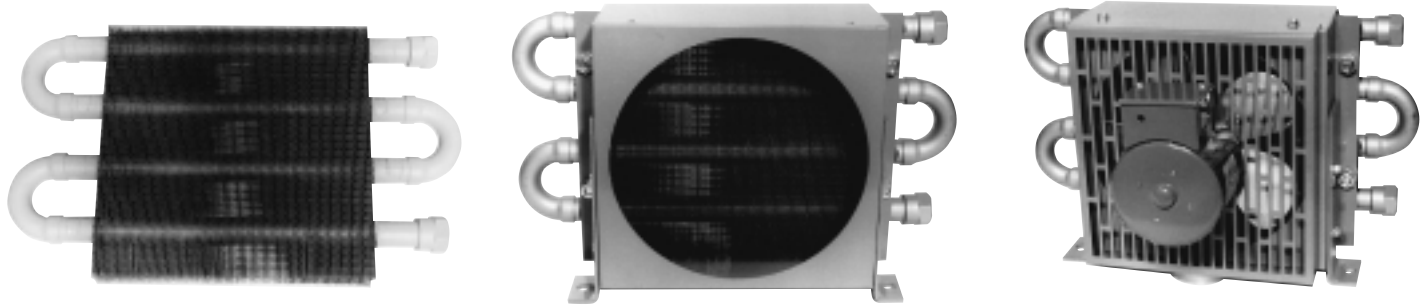

Many hydraulic power units recommend the operating temperature of the oil should not exceed 160° F. Excessive temperature can cause the oil to oxidize, forming gum, varnish, resins, sludge and acids. These by-products shorten the life of the oil, can cause valves to stick and cause erratic operation of the system. Also, excessive heat reduces the efficiency of the hydraulic system while consuming more energy.

*Use Air Oil Coolers to Cool:*  
 Fluid Power Systems  
 Gear Drives  
 Machine Tools  
 Torque Converters  
 Hydraulic Presses

### VESCOR Air Oil Coolers Come Complete

- Ready for installation
- Low cost - highly efficient designs
- Mounting brackets included with all models
- Readily available from stock

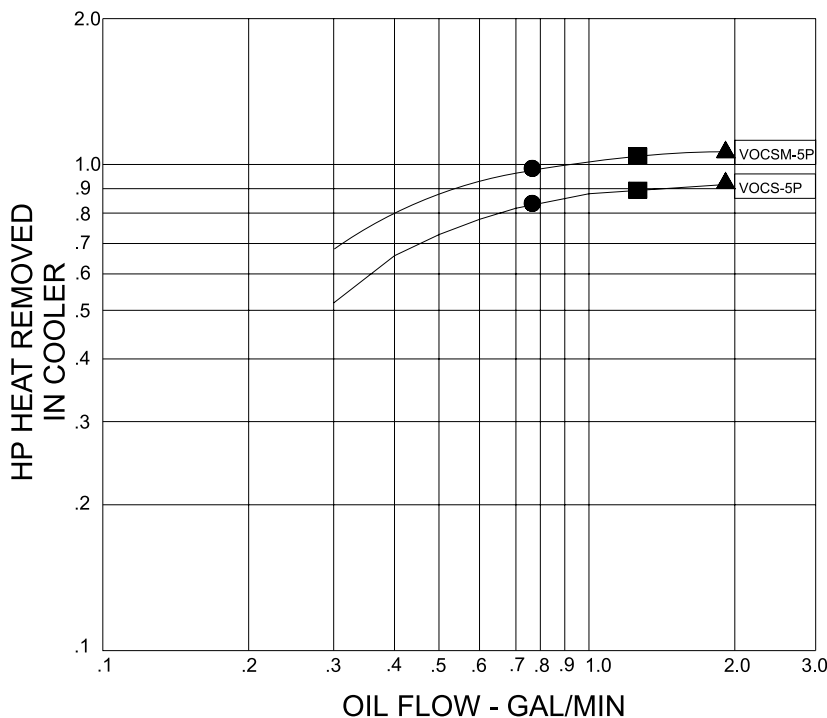

1. VOC-5-P PERFORMANCE: D-RATE VOCS-DP CURVE BY 25% (When used behind TEFC motor)
2. CURVES ARE BASED IN A 40°F APPROACH TEMPERATURE (oil out °F-amb air °F)
3. OIL PRESS DROP CODING
  - = 5 P.S.I.
  - = 10 P.S.I.
  - ▲ = 20 P.S.I.
4. AVERAGE OIL VISCOSITY = 100 SSU FOR PERFORMANCE RATING
5. ALL MODELS ABOVE:
  - MAXIMUM PRESSURES — 200 P.S.I.
  - MAXIMUM TEMPERATURE — 350°F

## OIL COOLER

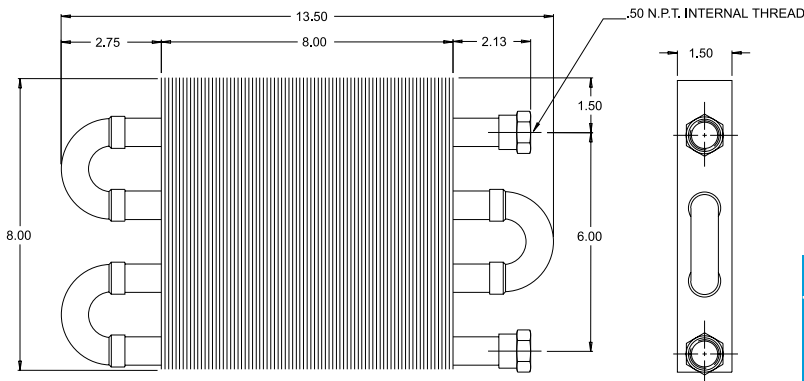

- Highly Efficient Design
- Rugged construction Resists Vibration
- Universal mounting bracket is included with cooler (hoses not included)

ORDER DATA / SPECIFICATIONS			
VESCOR PART NUMBER	FLOW RANGE GPM	HP HEAT REMOVED	SHIPPING WEIGHT
VOC-5-P	0.3-2	1.0	3.0

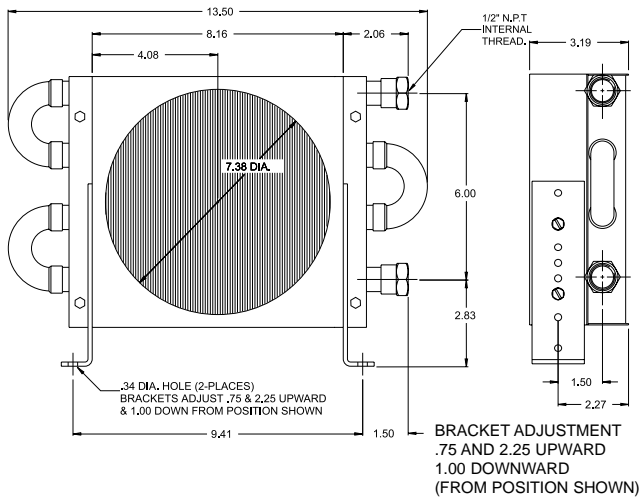

## TEFC REAR MOUNTED OIL COOLER

- Uses air stream from fan of electric motor
- Sized to fit popular electric motor frame sizes
- Durable powder painted cabinet
- Maximizes efficiency with contoured air side fins and internal oil turbulators
- Includes motor gasket and mounting bracket
- Fits Nema Frame sizes 48 thru 184T

ORDER DATA / SPECIFICATIONS			
VESCOR PART NUMBER	FLOW RANGE GPM	HP HEAT REMOVED	SHIPPING WEIGHT
VOCS-5-P	0.3-2	1.0	6.0

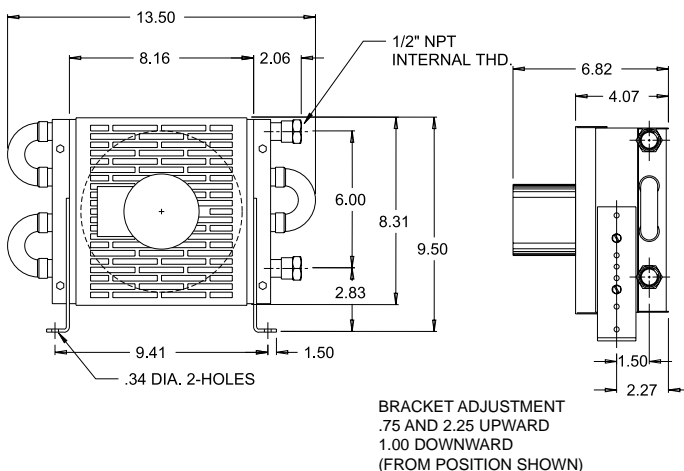

## FORCED AIR OIL COOLER

- Compact, highly efficient design with contoured side fins and internal oil turbulators
- Rugged construction resists vibration and stress
- Eliminates sewer and water costs
- Mounting bracket included for easy installation

ORDER DATA / SPECIFICATIONS			
VESCOR PART NUMBER	FLOW RANGE GPM	HP HEAT REMOVED	SHIPPING WEIGHT
VOCSM-5-P	0.3-2	1.0	13.0